

TAMD162A, TAMD162C, TAMD162C-B

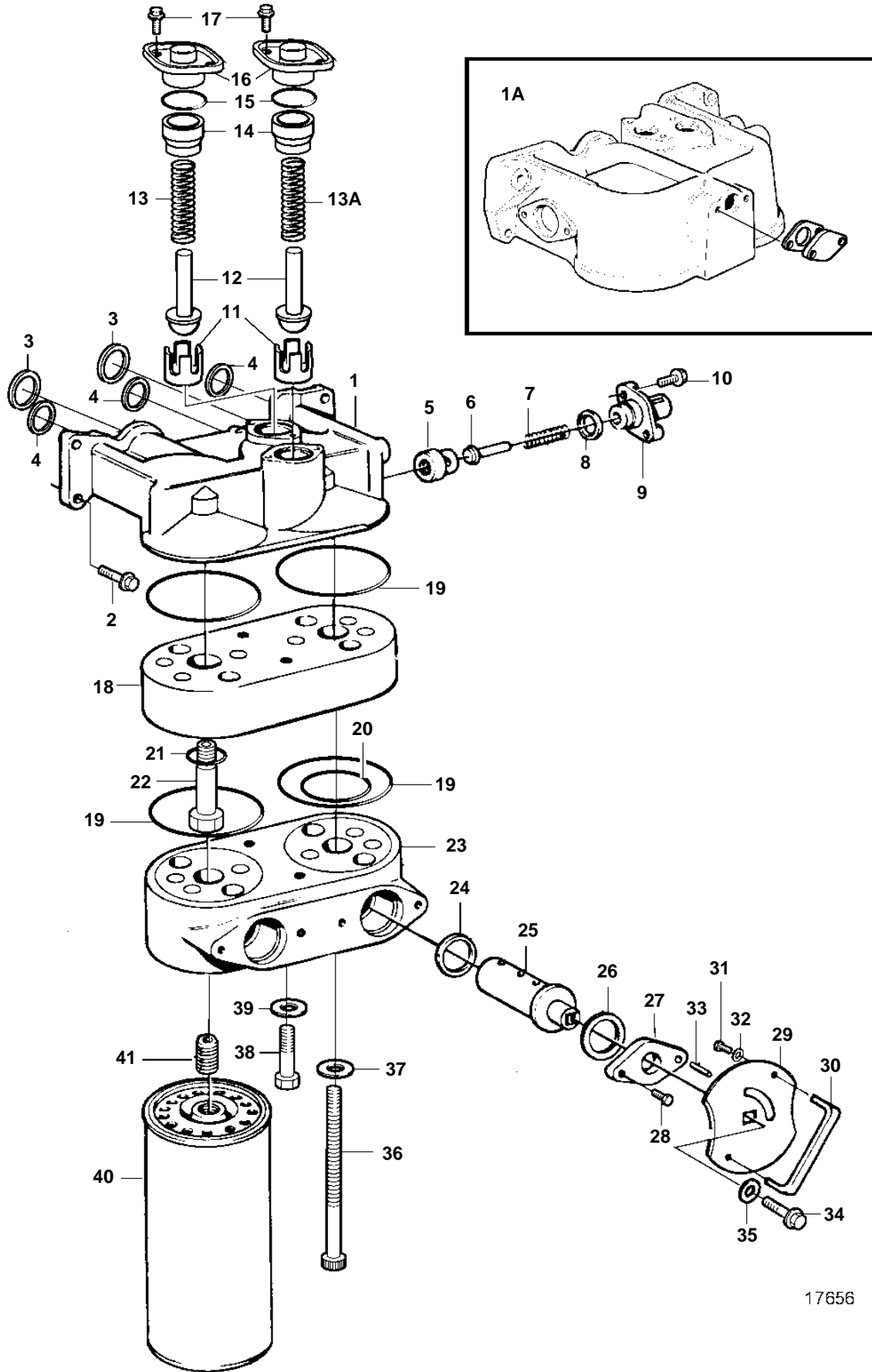

17656

TAMD162A, TAMD162C, TAMD162C-B

REF	PART NO.	QTY	DESCRIPTION	SEE SEC.	NOTES
1	1543466	1	Oil filter housing		REPL BY 3826150
1A	3826150			4177	
2	946671	4	Flange screw		
3	8192187	2	Sealing ring		
4	8192189	3	Sealing ring		
5	1543964	1	Valve seat		
6	1543610	1	Peg		
7	1543611	1	Spring		
8	1543577	1	Sealing ring		
9	1543608	1	Cover		
10	946671	2	Flange screw		
11	1542265	2	Seat		
12	471085	2	Valve		
13	1543642	1	Spring		To increase the flow through the piston cooling valve, spring 1543642 should be replaced by spring 466653.
	466653	1	Spring		
13A	466653	1	Spring		
14	1542266	2	Sleeve		
15	1543577	2	Sealing ring		
16	1542267	2	Cover		
17	945414	4	Screw		
18	862110	1	Attaching plate		
19	949647	4	O-ring		
20	969415	2	O-ring		
21	949016	2	Gasket		
22	864381	2	Fitting		
23	864486	1	Valve housing		
24	975309	2	O-ring		
25	864478	2	Valve peg		
26	962685	2	Washer		
27	862136	2	Flange		
28	946934	4	Flange screw		
29	862138	2	Lock plate		
30	862139	2	Handle		
31	956076	4	Screw		
32	941905	4	Spring washer		
33		2	Set screw		
34	967949	2	Screw		(965175)
35	960139	2	Washer		
36	959233	6	Screw		
37	947620	6	Gasket		
38	955285	2	Screw		
39	949607	2	Spring washer		
40	478736	2	Oil filter		
41	849040	2	Nipple		